

# SCANDINORDICA Disco Ball Diffuser

## Model name: Stella

Thank you for choosing our product. For the product's most effective use, please read the user manual carefully before using it.

### Product Structure Drawing

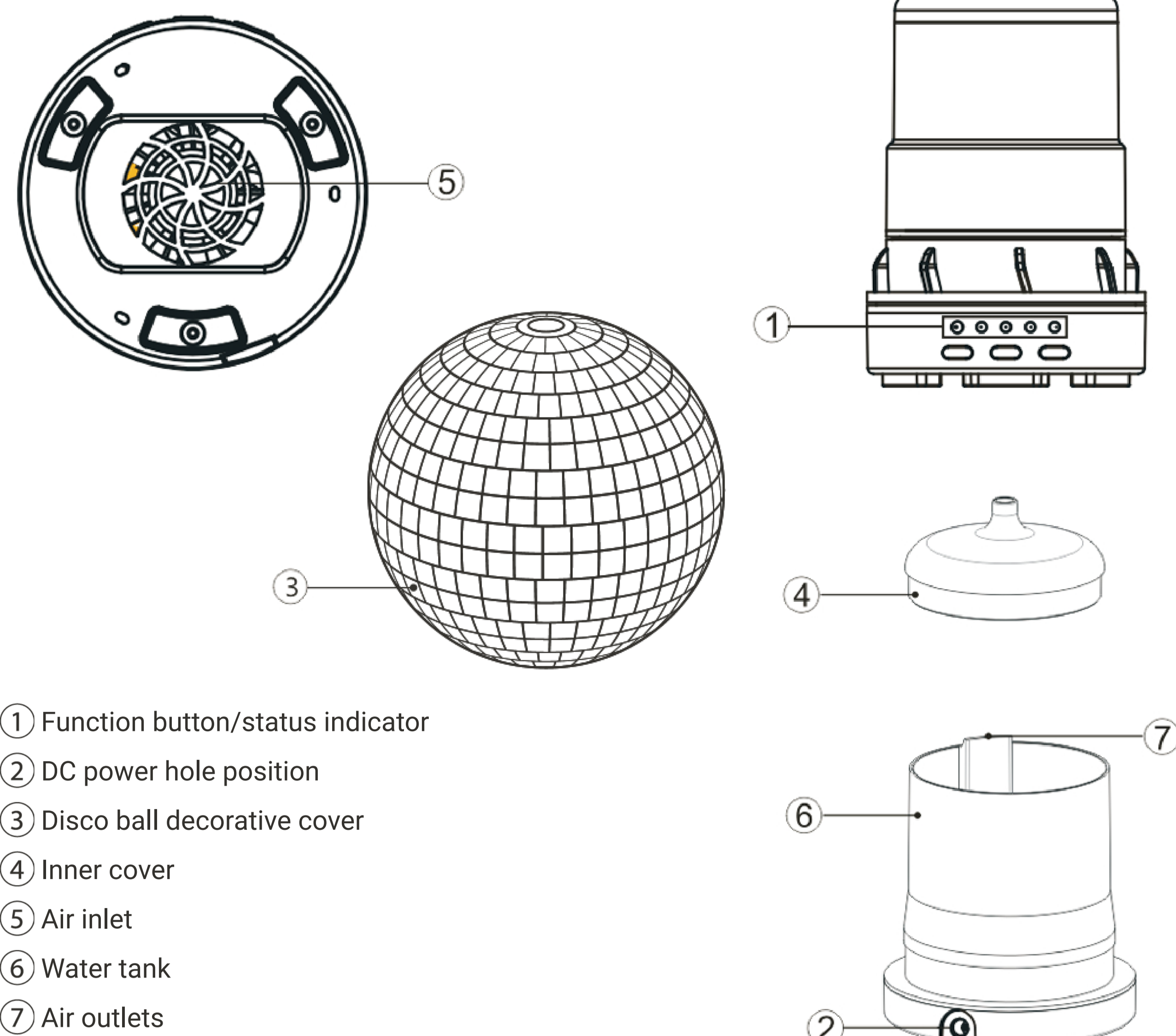

- ① Function button/status indicator
- ② DC power hole position
- ③ Disco ball decorative cover
- ④ Inner cover
- ⑤ Air inlet
- ⑥ Water tank
- ⑦ Air outlets

### Button Functions

#### Mist Control Switch

1. Press the button for the first time: set the timer for 1 hour
  2. Press the button for the second time: set the timer for 2 hours
  3. Press the button for the third time: set the timer for 3 hours
  4. Press the button for the fourth time: Intermittent spray (10-second spray, 10 seconds on stop).
- If the water in the water tank has been exhausted, the product will automatically power off.

#### LED light Control Switch

1. Press the button to change between 7 different colors.

#### Rotate Control Switch

1. Press the button for the first time: slow rotation (55 seconds/circle)
2. Press the button for the second time: fast rotation (30 seconds/circle)
3. Press the button for the third time: stop rotation

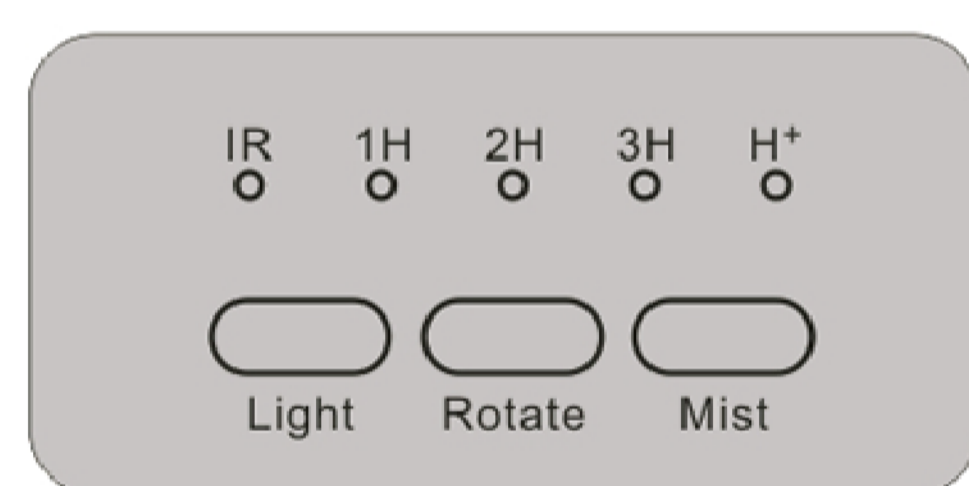

### Application Method

1. Take out the decorative disco ball cover and the inner cover in the direction of the arrow. When you take out the tank, there may be residual water from the last time you used it. Please keep the water tank upright to prevent the residual water from spilling out.

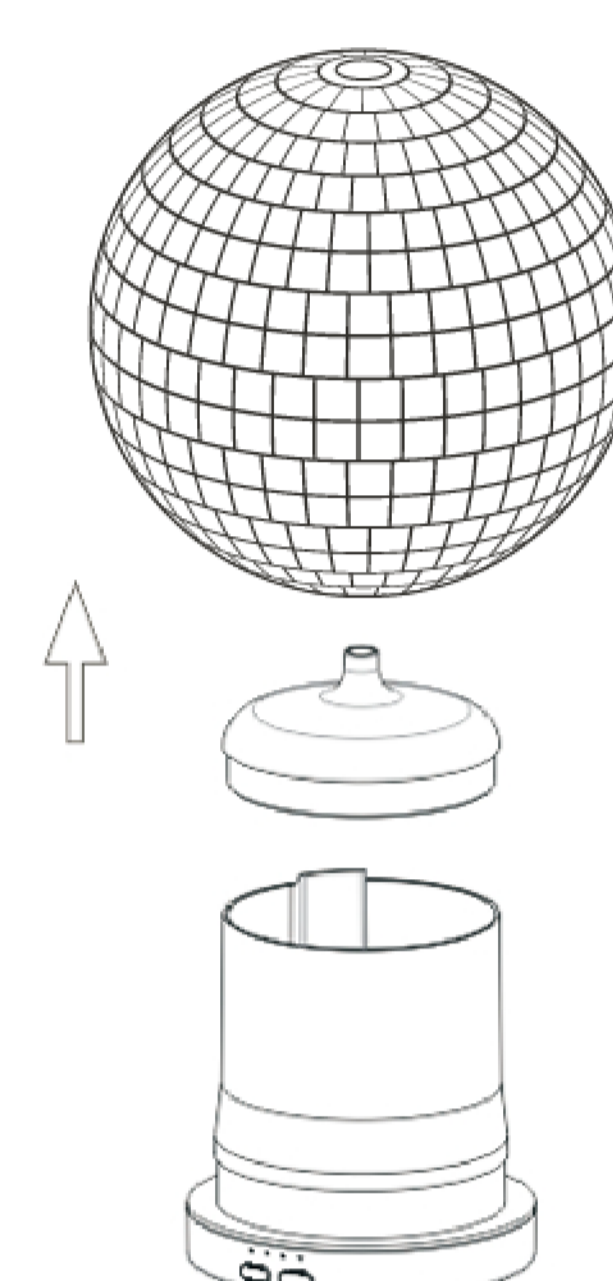

2. Fill the water tank without exceeding the water level maximum scale line, then add 2-3 drops of essential oil.

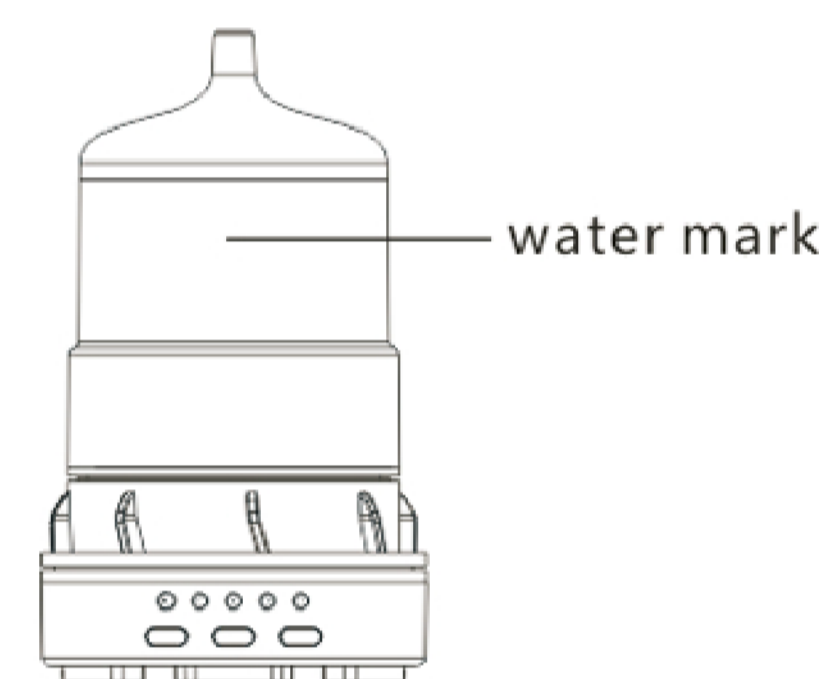

**Precautions for adding water:**  
Please add the appropriate amount of water according to the water level line. If the water addition exceeds the maximum scale, there will be no fog or smaller fog. Please choose pure water or clean tap water.

### Application Method

3. Install the decorative disco ball cover and inner cover in the direction of the arrow, and confirm that they are installed in place.

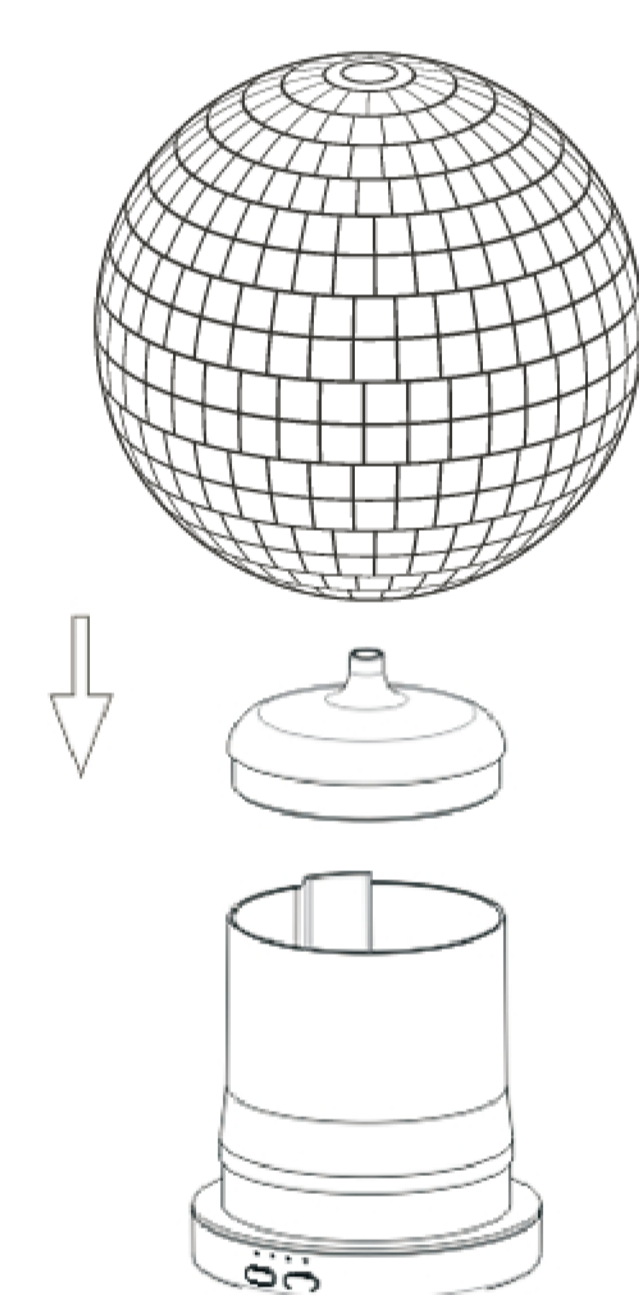

4. Insert the output plug of the power adapter into the DC power hole to connect to the power supply. Press the MIST key lightly to select the gear button required. The gear indicator light will light up and the product will enter the working state. Please make sure that the product is placed on a flat surface during use.

**Note:**  
When the water temperature and quality are affected by external factors, the amount of spray may be smaller at the beginning. After a few minutes, the volume of the spray can be restored to normal.

### Cleaning Method

1. Remove the power adapter from the socket, then remove the outer disco ball and inner tank cover.
2. Pour out the remaining water from the water tank. Be careful not to sprinkle the water into the air outlet at the bottom of the water tank.
3. Moisten the cloth with a neutral detergent diluted in warm water and then wring it out. Thoroughly wipe the machine and water tank cover.
4. When cleaning the bottom of the water tank, please use cotton swabs, etc

**Note:** Do not touch or press the ultrasonic panel at the bottom of the tank.

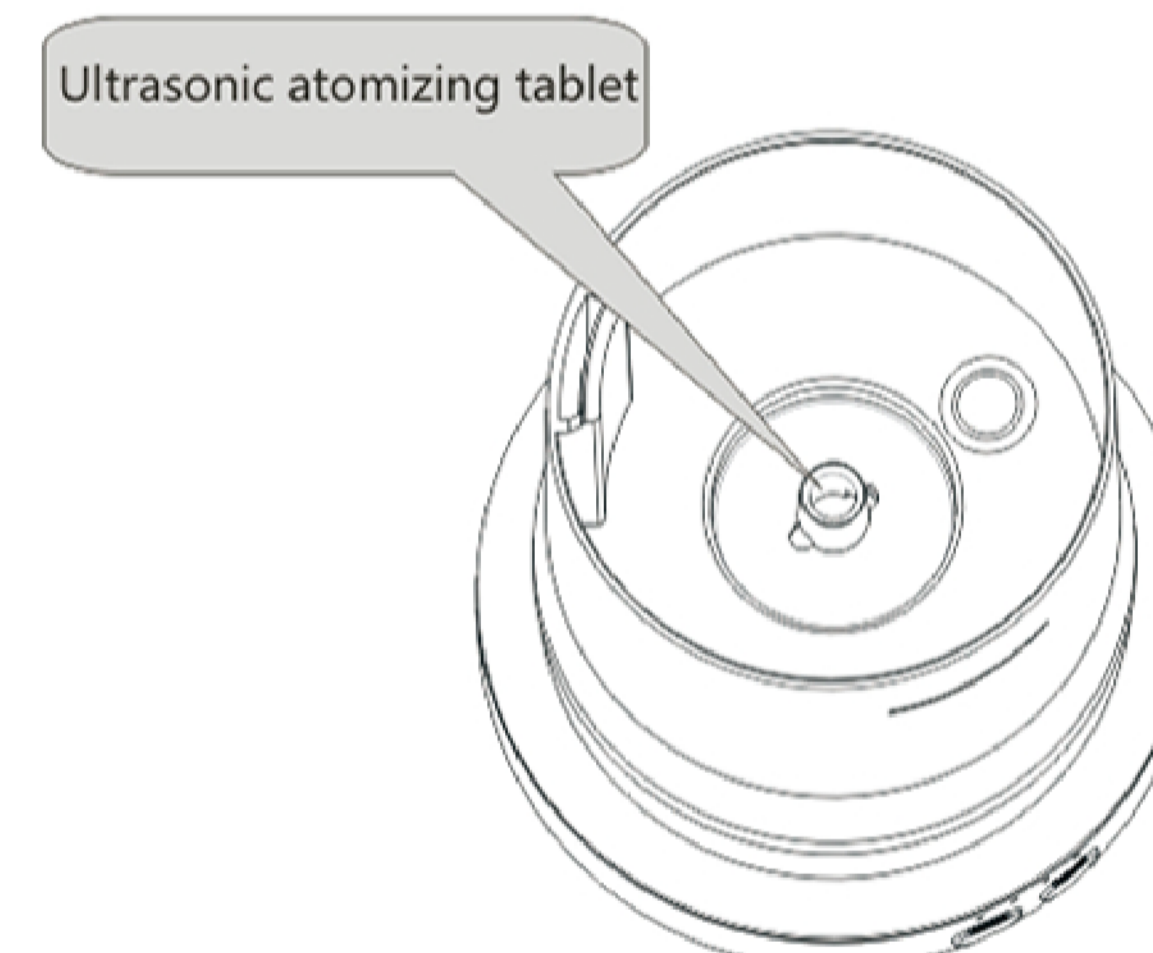

### Precautions for use

- Clean the water tank regularly. The bottom of the water tank can become dirty, which will cause faults. Clean it after every 6 uses (5-7 days).
- Do not move or tilt the machine when it is in operation, so it does not leak into the product so as not to leak into the inside of the product.
- To add water, it is necessary to open the cover of the inner tank. It is forbidden to add water through the fog hole directly to the tank.
- When the product is working, do not block the fog hole, the human body should not be placed above the fog hole for a long time, for it not to do harm.
- Water droplets may be attached to the tank cover inside the disco ball cover, and other components. Please be careful of water droplets spilling when opening.
- Be sure to unplug the power adaptor from the socket when the product is not in use.
- If not used for a long time, please keep the product in proper condition by thoroughly drying it.
- Please use essential oil with natural ingredients extracted from plants. Do not use perfume or synthetic perfume to avoid malfunction.
- When the water is added to the water tank, combine it with 2-3 drops of essential oil. If the amount of water is not enough, please add and subtract according to the actual amount of water
- Do not add essential oil under the condition of no water or very little water, to avoid failure.

### Technical parameters

Product Name: SCANDINORDICA Disco Ball Diffuser  
 Product Model: Stella  
 Product Size: 6.7" height x 6.0" width  
 Water tank Capacity: 90 ML  
 Nominal Voltage: DC24V  
 Product Weight: 1.2 lbs  
 Rated Current: 500MA

### Troubleshooting in use

If the machine has improper maintenance, refer to the following methods to solve the problem.

Malfunction	Method solve
No electricity, the power status light is not on.	Check if the power adapter is plugged into a power socket, And if the output plug is inserted into the machine.
The Machine doesn't start	Check if the tank has enough water. Check if the cover needs to be cleaned.
The Fog is too small	Check the tank for excess water. Check whether the ultrasonic transducer is covered by scale, and clean it if needed. Check if the bottom fan inlet is clogged, and clean it if needed.

### After-sales Service

Should you encounter any problems please reach out to our customer care team at: [support@scandinordica.com](mailto:support@scandinordica.com).

We respond to all inquiries within 24 hours.